

FlexiTune ***AutoX4***

Installation & User Manual

Introduction.....	3
Recommended tools before installation is performed	4
Connecting Flexitune.....	5
Installation guide – step by step.....	11
User’s guide	12
Fuel Mixture Detection.....	12
Cold Start	12
LED indicator.....	12
Injection valve saturation.....	12
Overcurrent	12
Advanced configuration.....	13
LED mode configuration	13
Advanced cold start adjustment settings.....	14

Introduction

Congratulations to the purchase of Flexitune! Now you can begin using your gasoline fueled vehicle in a more environmental way. Flexitune is designed in Sweden for tough environmental conditions. All components used in Flexitune comply with standards for more environmental friendly production. Using Flexitune is easy, you don't need to be an expert to succeed with you installation.

Please take the necessary time to read the whole manual before attempting to perform the installation!

Below is a picture of Flexitune:



Installation

This chapter will explain the installation procedure.

Important note:

It is important to check if the injector valves are low impedance. If the injector valve has about 1-6 ohms it is low impedance.

In this case it might be necessary to connect additional power resistors in series with the injection valve. Some injection systems with low impedance injection valves have external separate power resistors mounted and some has it integrated in the injection system ECU (computer).

If external resistors are present, Flexitune can be used without additional power resistors, but if no external resistors exists, extra power resistors with about 4-8 ohm and power rating of 20W must be added. (e.g. ELFA nr 60-048-65, www.elfa.se).

Recommended tools before installation is performed

1. **Small screwdriver** (2-3 mm tip) for adjusting the potentiometer
2. **Cable shoe pliers & cable shoes** (male & female type and ring type shoe)
3. **Cutting pliers**
4. **Knife**
5. **Cable** (aprox. 2-4 meters, 1.5 mm²)
6. **Multimeter**
7. **Adhesive tape**

Mounting location

The Flexitune unit should preferably be located away from direct water splashes and other unnecessary dirt, oil and wet conditions. A suitable location is close to the fire wall below the wind shield. It can also be mounted inside the passenger compartment.

Connecting Flexitune

Connection terminal specification

- 12V – +12 Volt
- GND – Chassis ground
- INJx – Injector number x
- ECUx – The car's engine management system (ECU) injector valve input x
- SEL – Lamda sond (oxygen sensor , EGO)
- BTN – Temperature sensor
- LED – Light emitting diode

Screw terminal marked *12V*

Connect Flexitune to a source that has power when the ignition is on **and when the engine is cranking**. For example the same power source as the injection valves, engine management system (ECU), fuel pump or ignition coil.

Note: Power must be supplied also when the engine is cranking!

Screw terminal marked *GND*

Connect securely to chassis ground.

Screw terminal marked *ECUx* ($x = 1$ to 4)

Shall be connected to the car's engine management system (ECU). The cable should, before conversion, lead to the injection valve from the car's ECU. The cable is cut or disconnected from the injector, then the end going to the ECU is connected to the terminal marked *ECUx* on Flexitune.

Screw terminal marked *INJx* ($x = 1$ to 4)

Shall be connected to the injection valve. The cable should, before conversion, lead to the injector from the car's ECU. The cable is cut or disconnected from the injector, then the end going to the injection valve is connected to the terminal marked *INJx* on Flexitune.

Make sure that for example ECU1 is matched with INJ1 for best performance.

Below is a picture that shows how Flexitune is connected to the injection valves and the car's engine management system (ECU).

Before installation:



After installation:

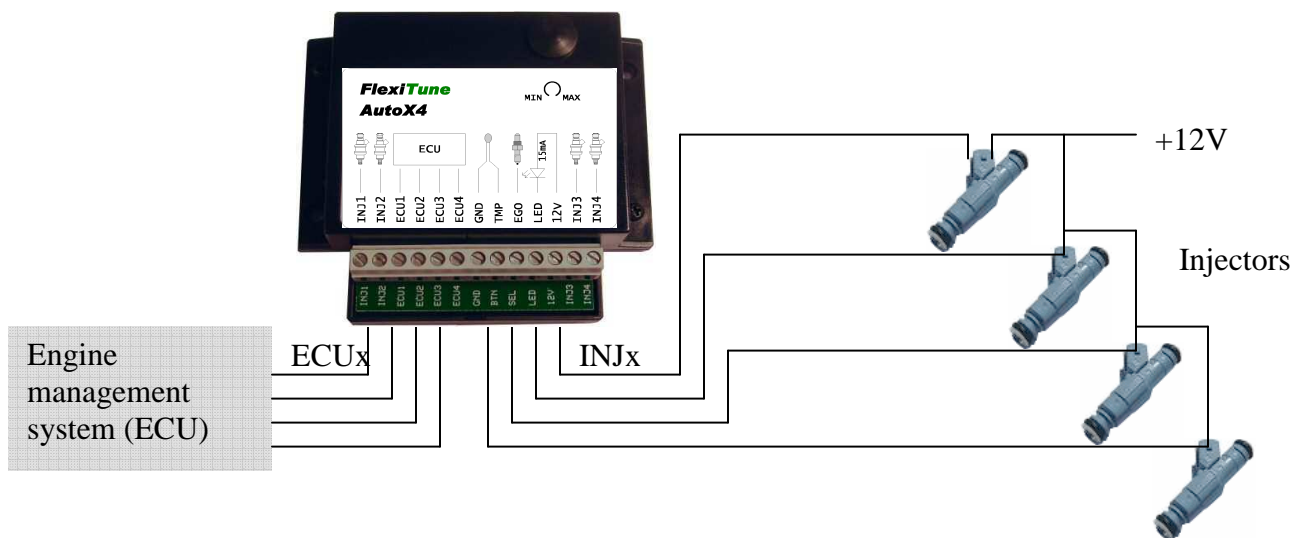

Special case with *low impedance* injectors

If the injection valves are **low impedance** and the engine management system has **built in power resistors**, additional resistors must be added in the injection valve circuit.

See important note on page 4 for more information.

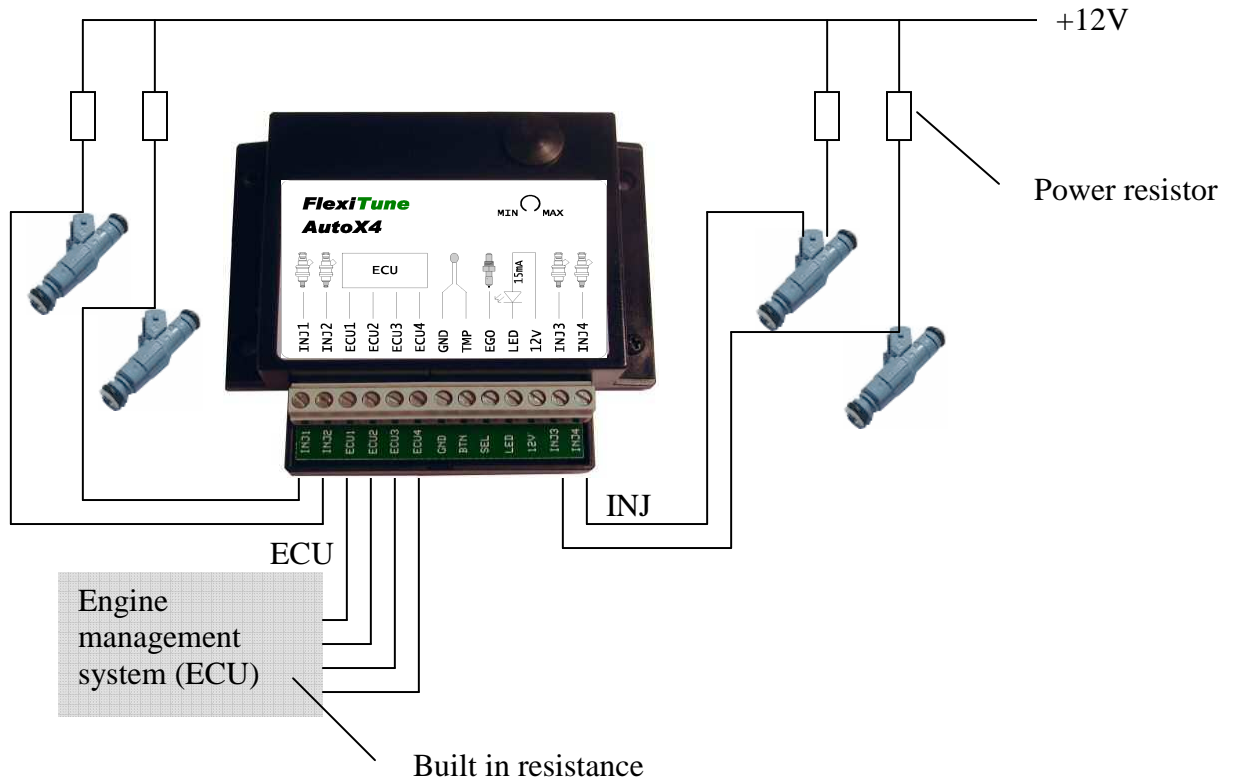

Screw terminal marked *BTN*

Normally it shall be connected to the temperature sensor. Connect the temperature sensor to GND and BTN terminal.

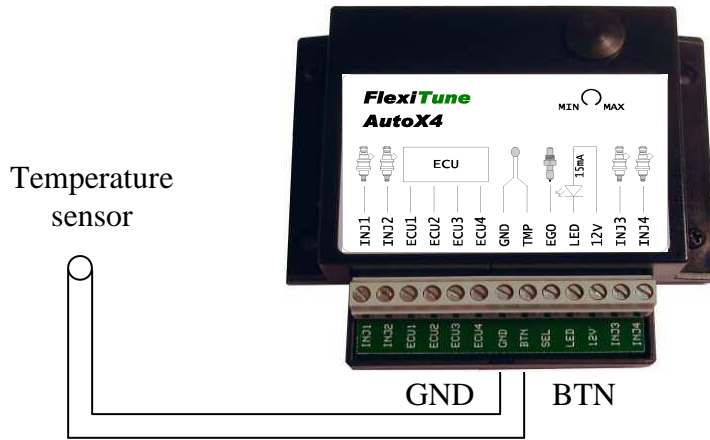

The BTN input can alternatively be connected to a button or switch instead of the temperature sensor. Connect the button or switch to GND and BTN terminal.

- When BTN is connected to GND it means that the engine warm.
- When BTN is not connected it means that engine is cold (BTN is open circuit).

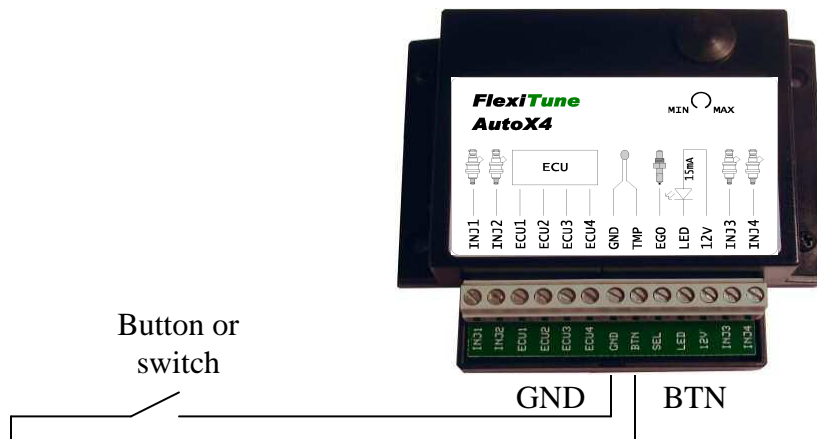

Screw terminal marked *SEL*

Connect SEL to the Lambda sensor (Exhaust gas oxygen sensor (EGO)).

Make sure that SEL is connected to the correct wire from the lambda sensor. The voltage shall be between 0-1V and change about once a second when the engine is hot. (Usually the signal is available in the black wire from the Lambda sensor).

Flexitune is connected in parallel with the cars engine management system.



The SEL input can alternatively be connected to an “on-on” switch connected to GND and 12V. This enables manual fuel selection accordingly:

- When SEL is connected to GND it means that the fuel mixture is 50-100% E85.
- When SEL is connected to 12V it means that the fuel mixture is 0-50% E85.

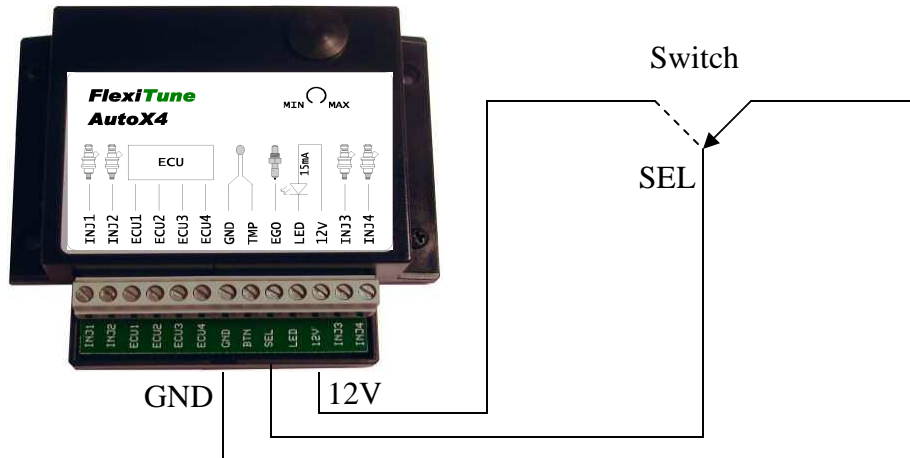

Screw terminal marked *LED (Optional)*
Connect a LED between 12V and LED

Note: The LED must be connected considering the LED's polarity!

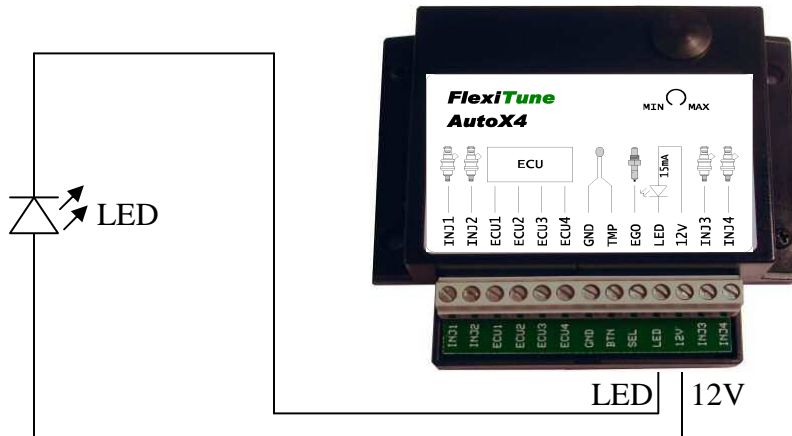

Installation guide – step by step

1. Connect **12V** on Flexitune to +12 V, preferably via the same power feeding as the injection valves, engine management system (ECU), fuel pump etc. Make sure that voltage is applied when engine is cranking.
2. Connect **GND** on Flexitune to chassis ground. Make sure to avoid long cables. Use a cable with at least 1.5 mm² area.
3. Disconnect **ALL** injection valve cable connectors (it is very important that all connectors remain disconnected during the voltage measurement).
4. Switch the ignition on (on some few cars the engine must be cranking) and measure the voltage between chassis ground and the two pins in one of the injection valve connectors. Note which pin that did **NOT** have +12V (It might be a little voltage on the pin but it should not be 12V).
5. Note the color of the cable that did **NOT** have +12V.
6. Switch ignition off.
7. Follow the cable that did **NOT** have +12V until you find a suitable place to connect Flexitune.
8. Cut the cable and mount cable shoes on the two cable ends. (Mount one insulated male and one female cable shoe for easy restoration of the cable).
9. Connect **INJx** on Flexitune to the cable end going to the injection valve (measure between the connector and the cable with a multi-meter set to ohm measurement setting to make sure that the right cable is connected. **Important:** leave all injection valve connectors disconnected during the measurement).
10. Connect **ECUx** to the other cable shoe going to the engine management system (ECU).
11. Reconnect all injection valve connectors.
12. Repeat 9 -10 for all **INJx and ECUx** connections.
13. Connect the temperature sensor to **GND** and **BTN** on Flexitune and use adhesive tape to attach the sensor to the radiator hose.
14. Connect the cars Lambda sensor the Flexitune screw terminal **SEL**.
15. **Double check all connections before the first start attempt.**

User's guide

Fuel Mixture Detection

Flexitune can automatically detect the mixture between gasoline and ethanol if the SEL input is connected to the car's Lambda sensor (EGO). The lambda sensor (EGO) should be of the type that indicates "rich" with 1V and "lean" with 0V. This sensor is also called "narrow band" Lambda sensor.

If it is not possible to connect SEL to the EGO sensor for some reason a switch can be used to manually tell Flexitune about the fuel mixture. Connect SEL to 12V for 0-50% E85 and connect SEL to 0V for 50-100% E85.

Cold Start

A temperature sensor can be connected to the BTN input to automatically activate the cold start functions when the engine is cold. Attach the temp sensor to the radiator hose and connect the two wires to GND and BTN.

It is possible to manually control the cold start functionality by connecting a switch between BTN and GND instead of the temp sensor. When BTN is connected to GND the engine is considered warm. When BTN is floating (not connected to anything) the engine is considered cold.

LED indicator

The LED can show the Flexitune operational status and other useful information during testing and installation. The LED can be configured in three different modes:

1. Normal mode
 - a. Flexitune power up indication
 - b. Fuel injection valve saturation indication
 - c. Injection circuit overcurrent indication
2. Supply voltage and temperature sensor test mode
3. Lambda sensor indication (EGO) test mode

For more information about the different LED modes see [Advanced configuration](#)

Injection valve saturation

This indication is activated when the injectors has reached the maximum injection flow. This can be good to know when the engine is subjected to high load due to heavy cargo or a connected trailer etc. Avoid running the engine continuously with this indication active. Activation during short periods, like when accelerating while overtaking etc is normal.

Overcurrent

This indication is activated if the current through the injector circuit is too high. If activated there is probably a short circuit in the cable harness or malfunction of one of the injectors.

Advanced configuration

LED mode configuration

The function of the LED can be configured with jumpers.



Jumper setting for Normal mode (No jumpers)

The LED lights up for 1.5 seconds at startup to show that Flexitune has started. After that the LED is normally off.

Two extraordinary conditions are indicated by the LED:

- If the injection valves have reached their maximum capacity the LED blinks quickly (- - - -). The injectors are continuously active which means that the engine may not get enough fuel.
- Overcurrent (LED active for three seconds). Too high current has been detected in one or more of the injector circuits. Flexitune switches off the injector circuit for three seconds to protect the internal components.



Jumper setting for supply voltage and temperature sensor test mode

The LED shows when Flexitune is powered up and also indicates if the engine is considered warm or cold. This mode can be used during installation and configuration to check that supply voltage is available when expected and that the temperature sensor is correctly connected.

- LED on Flexitune is powered up & engine is hot.
- LED blinks - - - - Flexitune is powered up & engine is cold.



Jumper setting for Lambda sensor indication (EGO) test mode

The LED shows the signal from the EGO. This mode can be used during installation and configuration to check that the wire from the EGO is correctly connected. When the engine is running the LED should blink. A normal blink rate is about one blink per second. Variations are normal - as long as the LED is not constantly on or off.

- LED off EGO indicates lean fuel mixture
- LED on EGO indicates rich fuel mixture

Procedure for adjusting the LED mode:

1. Use one of the above jumper settings to select LED mode
2. Selection is complete

Advanced cold start adjustment settings

In cold conditions the engine may be difficult to start with E85 due to the fuel properties. Several attempts to start may be required. Flexitune has built in cold start features that are user configurable. Flexitune supports two configurable settings that improve the cold start when starting the engine with E85:

1. On start enrichment setting (during cranking)
2. Engine running cold enrichment (after engine is started but still cold)

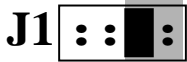

Jumper setting for storing *On Start enrichment* value from potentiometer



Jumper setting for storing *Engine running cold enrichment* value from potentiometer

Procedure for adjusting the cold start parameters:

1. Use one of the above jumper settings to select which parameter that shall be adjusted.
2. Set the potentiometer to the desired value between zero(left) and max (right)
3. Power up Flexitune (e.g. ignition on)
4. Power down Flexitune (e.g. ignition off)
5. Adjustment for the selected parameter is completed
6. Remove all jumpers that controls cold start (jumper 3 and 4)
7. (Repeat 1-6 for next cold start setting if desired)

Note: It is possible to keep one jumper setting permanent during adjustment and driving. A new potentiometer value is then read for the specific parameter each time the car is started.